

# Bends

# BPL/BP-60



## Description

BPL – pressed bend, seam-welded and calibrated, with double EPDM gasket .  
 BP – pressed bend, seam-welded and calibrated, without gasket .

### Example identification

Product code: **BPL - aaa - 60**



## Technical Data

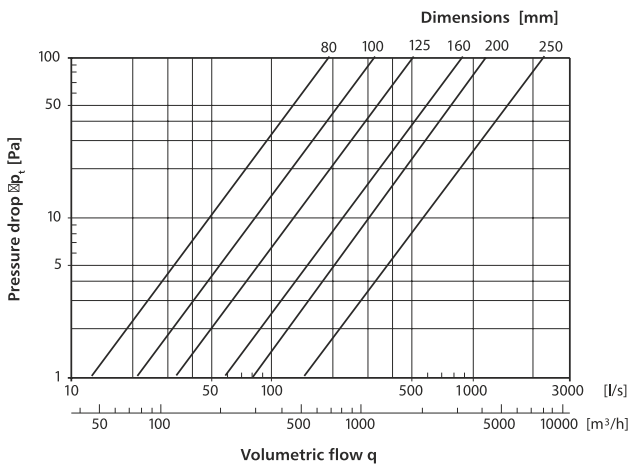

## Dimensions

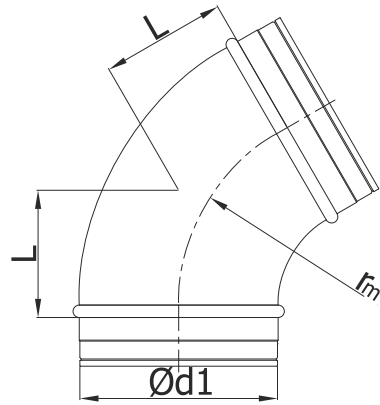

$r_m \text{ } \varnothing 1 \times d_1$

$\varnothing d_1$ rated	L [mm]	weight [kg]
80	64	0,3
100	64	0,4
125	72	0,5
140	78	0,6
150	87	0,9
160	92	1,0
180	104	1,2
200	115	1,5
250	144	2,2